

Thank you for purchasing a Sealey product. Manufactured to a high standard this product will, if used according to these instructions and properly maintained, give you years of trouble free performance.



IMPORTANT: PLEASE READ THESE INSTRUCTIONS CAREFULLY. NOTE THE SAFE OPERATIONAL REQUIREMENTS, WARNINGS & CAUTIONS. USE THE PRODUCT CORRECTLY AND WITH CARE FOR THE PURPOSE FOR WHICH IT IS INTENDED. FAILURE TO DO SO MAY CAUSE DAMAGE AND/OR PERSONAL INJURY AND WILL INVALIDATE THE WARRANTY. PLEASE KEEP INSTRUCTIONS SAFE FOR FUTURE USE.

1. SAFETY INSTRUCTIONS

- ✓ Always load evenly with the centre of gravity of the load as near the centre and rear of the plate as possible.
- ✓ Obtain additional support for large or wide loads to prevent tipping.
- ✗ Do not overload the truck - see Specification.
- ✗ Do not leave unattended, especially when loaded, unless the wheels are chocked or the truck is otherwise secured.
- ✗ Do not use truck on uneven ground and do not run over curbs or steps - use a ramp.
- ✗ Do not allow others to ride on the truck.
- ✗ Do not use the truck if any part is damaged, paying particular attention to the wheels.

2. SPECIFICATION

Model No.	CST989
Max. Load	250kg
Wheel Diameter	250mm
Wheel Thickness	75mm
Height	1275mm
Overall Width	600mm
Platform Depth	300mm

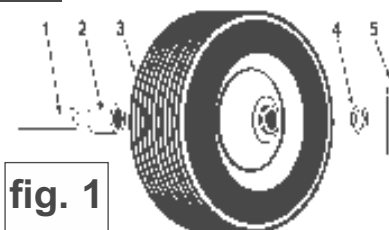

fig. 1



fig. 2

3. ASSEMBLY

- 3.1. Make sure the axle is free from dust and dirt to allow free rotation of the wheel.
- 3.2. Place spacer (fig. 1.2) onto axle first. Slide the wheel (fig. 1.3) onto the axle followed by a washer (fig. 1.4). Push a split pin (fig. 1.5) through the hole in the end of the axle and bend over the ends in order to secure the whole assembly.
- 3.3. Repeat for the other side.

4. TRUCK OPERATION

- 4.1. The truck can be used in three different configurations as shown in figs. 2, 3 & 4.
- 4.2. **Standard Sack Truck.** To operate as a two wheel sack truck ensure that the castor wheels and secondary frames are secured flat against the main frame. The castor wheels should be turned sideways and the loop handle should be resting in the lower stowage bracket with the locking pin in place, as shown in fig. 2.
- 4.3. **Sack Truck supported at 45°.** To use as a 45° sack truck release the secondary frame and wheels by removing the locking pin from the lower bracket. Take hold of the loop handle with one hand and tip the truck towards you with the other hand until the loop handle can be placed into the upper bracket and secured with the locking pin, as shown in fig. 3.
- 4.4. **Flat bed truck.** To use as a flat bed truck release the secondary frame and castor wheels by removing the locking pin from the securing bracket. Take hold of the loop handle and tip it towards you so that it clears the square tube at the top of the main frame between the black handles. With the other hand lower the main frame until the square tube comes to rest on the slotted bracket about 12cm above the castor wheels, as shown in fig. 4. Fold up the load restraint at the other end of the frame until it rests against the platform. Manoeuvre the loaded trolley using the loop handle only. Do not lift the truck by the black handles when used in flat bed configuration.



fig. 3

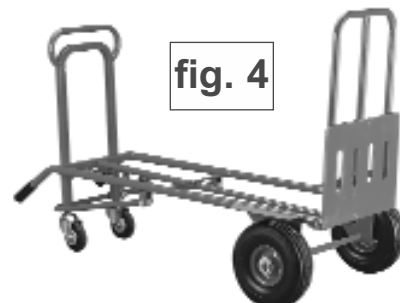

fig. 4

5. PARTS

The following spare parts can be ordered for the CST989:-

Pneumatic Tyre: - **CST989/FW** Castor Wheel: - **CST989/CW** Frame: - **CST989/01**

NOTE: It is our policy to continually improve products and as such we reserve the right to alter data, specifications and component parts without prior notice.
IMPORTANT: No liability is accepted for incorrect use of product. **WARRANTY:** Guarantee is 12 months from purchase date, proof of which will be required for any claim. **INFORMATION:** For a copy of our latest catalogue and promotions call us on 01284 757525 and leave your full name and address including your postcode.

