

Thank you for purchasing a Sealey Product. Manufactured to a high standard this product will, if used according to these instructions and properly maintained, give you years of trouble free performance.

**IMPORTANT:** PLEASE READ THESE INSTRUCTIONS CAREFULLY. NOTE THE SAFE OPERATIONAL REQUIREMENTS, WARNINGS AND CAUTIONS. USE THIS PRODUCT CORRECTLY AND WITH CARE FOR THE PURPOSE FOR WHICH IT IS INTENDED. FAILURE TO DO SO MAY CAUSE DAMAGE OR PERSONAL INJURY AND WILL INVALIDATE THE WARRANTY. PLEASE KEEP INSTRUCTIONS SAFE FOR FUTURE USE.

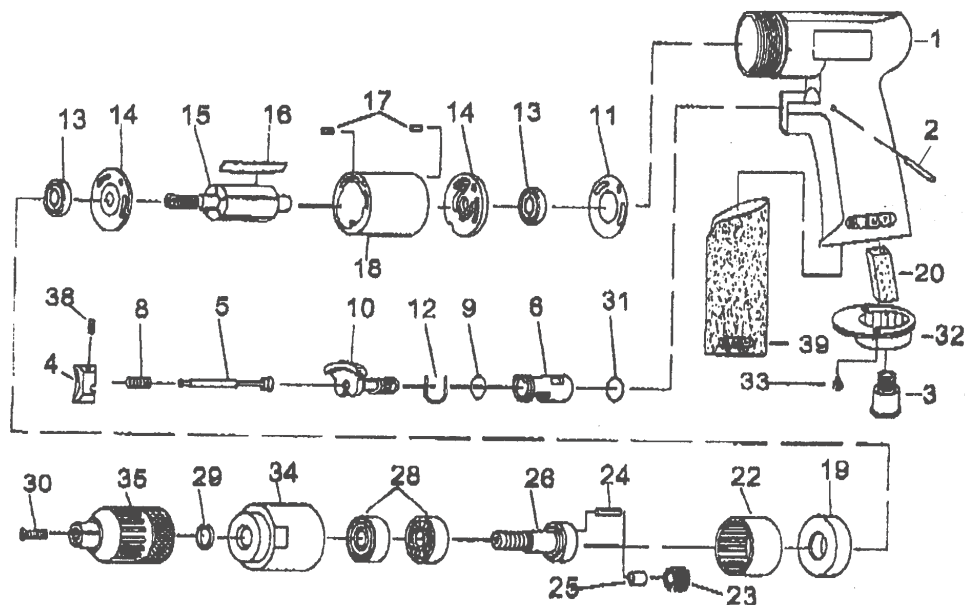

Item	Part No	Description	Item	Part No	Description
1	SA620/01	MOTOR HOUSING	22	SA620/22	INTERNAL GEAR
2	SA620/02	PIN	23	SA620/23	PLANET GEAR
3	SA620/03	AIR INLET	24	SA620/24	PIN
4	SA620/04	TRIGGER	25	SA620/25	BUSHING
5	SA620/05	VALVE STEM SET	26	SA620/26	WORK SPINDLE
6	SA620/06	REVERSE BUSHING	28	SA620/28	BALL BEARING
8	SA620/08	VALVE SPRING	29	SA620/29	CHUCK SPACER
9	SA620/09	O-RING	30	SA620/30	CHUCK SCREW
10	SA620/10	REVERSE LEVER	31	SA620/31	O-RING
11	SA620/11	MOTOR GASKET	32	SA620/32	EXHAUST DIFFUSER
12	SA620/12	REVERSE RETAINER	33	SA620/33	SCREW
13	SA620/13	BALL BEARING	34	SA620/34	CLAMP NUT
14	SA620/14	END PLATE	35	SA620/35	KEYLESS CHUCK
15	SA620/15	ROTOR	38	SA620/38	SET SCREW
16	SA620/16	ROTOR BLADES	39	SA620/39	RUBBER GRIP
17	SA620/17	SPRING PIN			
18	SA620/18	CYLINDER			
19	SA620/19	SPACER			
20	SA620/20	DAMPING MATERIAL			

**NOTE:** It is our policy to continually improve products and as such we reserve the right to alter data, specifications and component parts without prior notice. **IMPORTANT:** No liability is accepted for incorrect use of this equipment. **WARRANTY:** Guarantee is 12 months from purchase date, proof of which will be required for any claim. **INFORMATION:** Call us for a copy of our latest catalogue and promotions on 01284 757525 and leave your full name and address including your postcode.

## 1. SAFETY INSTRUCTIONS

- Follow all workshop health & safety rules, regulations, and conditions when using drill.
  - WARNING!** Disconnect from air supply before changing accessories or servicing.
- Maintain the drill in good condition and replace any damaged or worn parts. *Use genuine parts only. Non-authorized parts may be dangerous and will invalidate the warranty.*
  - WARNING!** Check correct air pressure is maintained and not exceeded. We recommended 90 psi.
- Keep air hose away from heat, oil and sharp edges. Check air hose for wear before each use and ensure that all connections are secure.
- Wear approved safety eye protection. If dust is generated wear respiratory protection, and safety gloves.
- Keep drill bits clean and sharp for best and safest performance.
- Maintain correct balance and footing. Ensure the floor is not slippery and wear non-slip shoes.
- Secure non stable work piece with a clamp, vice or other adequate holding device.
- Ensure the chuck is securely fastened to the spindle and the drill bit is secure in the chuck.
- Keep children and unauthorised persons away from the working area.
- DO NOT get the drill wet or use in damp or wet locations.
- DO NOT hold the workpiece by hand. Use clamps or a vice to secure the workpiece.
- DO NOT use the drill for a task it is not designed to perform.
  - WARNING! DO NOT** use drill if damaged or faulty. Contact your local service agent.
- DO NOT use drill unless you have been instructed in its use by a qualified person.
- DO NOT drop, throw or abuse the drill.
- DO NOT carry the drill by the air hose, or yank the hose from the air supply.
- DO NOT operate drill if you are tired, under the influence of alcohol, drugs or intoxicating medication.
- DO NOT carry drill with your hand on the power trigger in order to avoid unintentional starting.
- DO NOT direct air from the air hose at yourself or others.
- When not in use disconnect from air supply and store in a safe, dry, childproof location.

## 2. INTRODUCTION & SPECIFICATIONS

Fully polished finish with exhaust through handle base for reduced noise emission. Smooth air motor runs on high quality ball bearings for long life and reliability. Fully reversible drive with finger-tip control set above trigger. Fitted with Jacobs keyless chuck for fast bit changes. Rubber grip gives added control.

Chuck size ..... 3/8"  
 Free speed ..... 1620rpm  
 Air consumption ..... .4cfm

Operating pressure ..... .90psi  
 Air inlet size ..... 1/4" BSP  
 Weight ..... .1.1 kg

### 3. PREPARING DRILL FOR USE

#### 3.1. Air Supply

- 3.1.1. Ensure drill air valve (or trigger) is in the "off" position before connecting to the air supply.
- 3.1.2. You will require an air pressure of 90psi, and an air flow according to specification.
- 3.1.3. **WARNING!** Ensure the air supply is clean and does not exceed 90 psi while operating the drill. Too high an air pressure and unclean air will shorten the product life due to excessive wear, and may be dangerous causing damage and/or personal injury.
- 3.1.4. Drain the air tank daily. Water in the air line will damage the drill.
- 3.1.5. Clean air inlet filter weekly. Recommended hook-up procedure is shown in fig 1.
- 3.1.6. Line pressure should be increased to compensate for unusually long air hoses (over 8 metres). The minimum hose diameter should be 1/4" I.D. and fittings must have the same inside dimensions.
- 3.1.7. Keep hose away from heat, oil and sharp edges. Check hose for wear, and make certain that all connections are secure.

#### 3.2. Couplings.

Vibration may cause failure if a quick change coupling is connected directly to the drill. To overcome this, connect a leader hose to the drill. A quick change coupling may then be used to connect the leader hose to the air line recoil hose. See fig 1 & 2.

fig 1

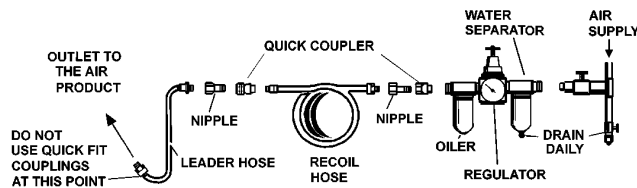
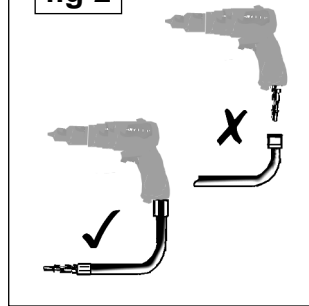

fig 2



### 4. OPERATING INSTRUCTIONS

**WARNING!** Ensure you read, understand and apply safety instructions before use.

- 4.1. Turn front of chuck head to open, insert drill bit and turn chuck head to lock drill bit.
- 4.2. Connect the drill to the air hose as in chapter 3.
- 4.3. The drill direction is changed by switching the reverse lever behind the trigger. Check that the drill is set to operate in the required direction.
- 4.4. Depress the trigger to operate the drill accordingly.

DO NOT allow drill to free run for an extended period of time as this will shorten its life.

### 5. MAINTENANCE

- WARNING!** Disconnect drill from air supply before changing accessories, servicing or performing maintenance. Replace or repair damaged parts. *Use genuine parts only. Non-authorized parts may be dangerous and will invalidate the warranty.*
- 5.1. Lubricate the air drill daily with a few drops of Sealey air tool oil dripped into the air inlet to prolong its life.
  - 5.2. Clean the drill after use.
  - 5.3. Loss of power or erratic action may be due to the following:
    - a) Excessive drain on the air line. Moisture or restriction in the air pipe. Incorrect size or type of hose connectors. To remedy check the air supply and follow instructions in chapter 3.
    - b) Grit or gum deposits in the drill may also reduce performance. If your model has an air strainer (located in the area of the air inlet), remove the strainer and clean it. Flush the drill out with gum solvent oil or an equal mixture of SAE No 10 oil and paraffin. Allow to dry before use.
  - 5.4. For a full service contact your local Sealey service agent.
  - 5.5. When not in use, disconnect from air supply, clean drill and store in a safe, dry, childproof location.

## Declaration of Conformity



We, the sole importer into the UK, declare that the product listed here is in conformity with the following EEC standards and directives. The construction file for this product is held by the Manufacturer and may be inspected, by a national authority, upon request to Jack Sealey Ltd.

**Air Reversible Pistol Drill**

**Model: SA620**

98/37/EC Machinery Directive  
93/68/EEC Marking Directive

Signed by Mark Sweetman

1st July 2000

For Jack Sealey Ltd. Sole importer into the UK  
of Sealey Power Tools.